

CLASSEUR VERTICAL / VERTICAL FILE		
DIMENSION		
LARGEUR / WIDTH		18"
PROFONDEUR / DEPTH		28"
HAUTEUR / HEIGHT		27 1/2"

44-02-182824

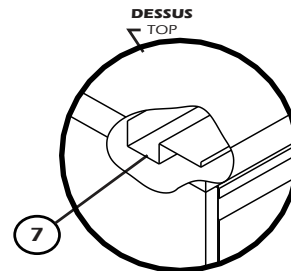

RENFORT DE DESSUS  
TOP REINFORCEMENT

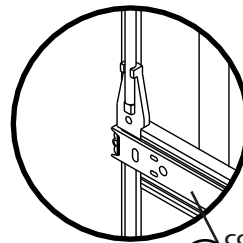

COULISSE DE TIROIR  
DRAWER RUNNERS

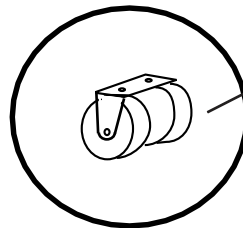

ROULETTE DOUBLE /  
DOUBLE CASTERS

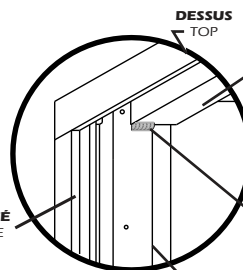

RENFORT DE CÔTÉ  
SIDE REINFORCEMENT

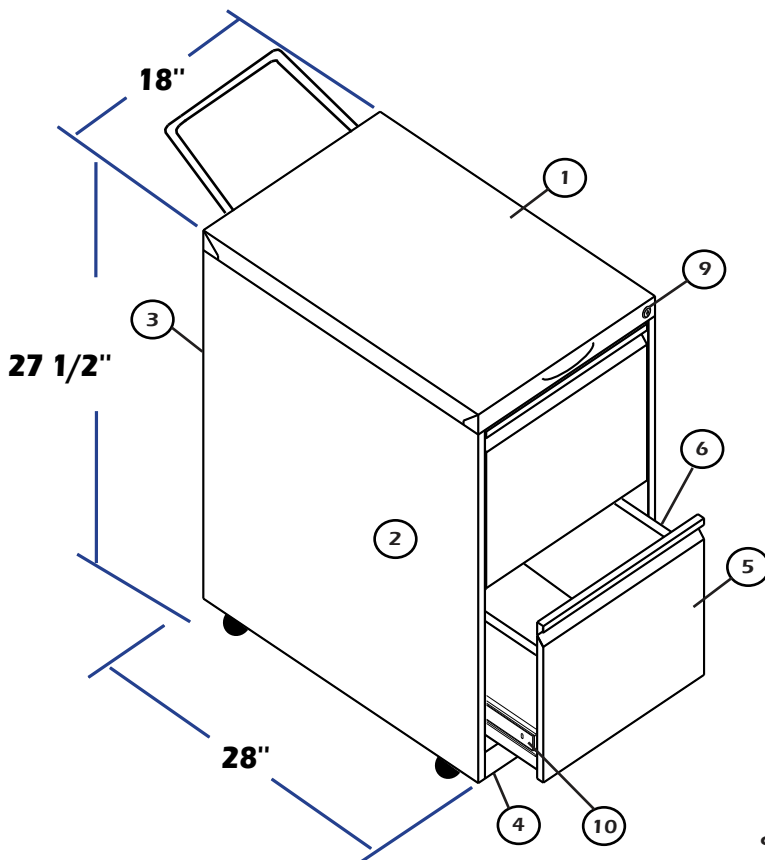

**CAISSON TAXI / TAXI PEDESTALS**

**SÉRIE 44 SERIES**

ENTIÈREMENT SOUDÉ / ALL WELDED

**SPECIFICATIONS**

ITEM	DESCRIPTION	MATER.	REQ.(✓)
1	Dessus / Top	20G. c.r.s.	✓
2	Côté / Side	20G. c.r.s.	✓
3	Dos / Back	20G. c.r.s.	✓
4	Fond / Bottom	16G. c.r.s.	✓
5	Devant tiroir / Front drawer	20G. c.r.s.	✓
6	Tiroir / Drawer	20G. c.r.s.	✓
7	Renfort dessus / Top reinforcement	18G. c.r.s.	✓
8	Renfort côtés / Side reinforcement	18G. c.r.s.	✓
9	Serrure / Lock		✓
10	Coulisse de tiroir / Drawer slides		✓
11	Roulette double / Double casters		4

**OPTIONS**

\*\*\* A.R.F. = ACIER ROULÉ À FROID / \*\*\* C.R.S. = COLD ROLL STEEL

**FINITION/FINISH**

Peinture : Émail cuit au four / Paint : Baked enamel

Couleur / Color : A DÉTERMINER / TO BE DETERMINED

Client :

Responsable :

Architecte / Ingénieur :

Architect / Engineer :

Projet / Project :

Approuvé par / Approved by :

Révision / Revision :

Date:



**PERFIX INC.**

VESTIAIRES ET MOBILIER MÉTALLIQUE  
LOCKERS AND METAL FURNITURE

Tel.: (450) 435-0540  
www.perfix.ca

Ce dessin technique est la propriété de Perfix et ne peut être reproduit sans autorisation.  
This technical drawing is the property of Perfix and may not be reproduced without permission.